

Xprimo®

A new generation of solid punch rivets



Nedschroef Xprimo rivets require no pre-drilled holes, yet offer robust, lasting joints making them ideal for automotive mass-production applications. The material used to create Xprimo allows application of many different types of coating. A little well-applied pressure is all Xprimo requires to penetrate not only solid metal, but a variety of other materials, too.

This offers significantly greater design flexibility. Light alloys can be joined to solid steel, for example, reducing weight without making any concessions to construction quality. Xprimo can be easily integrated into existing manufacturing processes and rivets are available in 4 mm and 5 mm shaft diameters and lengths of 3,5 mm up to 9 mm. Alternative sizes and bespoke shapes are available on request.

An integrated range of modular industrial riveting products may be obtained from our partner company TOX Pressotechnik GmbH & Co.KG. www.tox-uk.com

FIELD OF APPLICATION

Xprimo can join together all types of sheet metal, made from a variety of materials (aluminum, steel, carbon fiber), of all thicknesses and strengths, including triple or multi-layered sheets. Xprimo is also highly suitable for fixing bonded sheet metal. Even before the adhesive has dried, Xprimo provides improved handling strength for further processing. Possible applications include riveting of transmission and front end components to the chassis, attaching fortified plates to vehicle doors and A or B or C pillars.

- Rear mounting plates on the vehicle, reinforcing plates in boot covers and bonnets
- Riveting metal plates to the seat base frame, fixing reinforcement plates to seat backs, attaching metal components for the seat reclining mechanism

For more information: www.nedschroef.com

FITTING PROCESS

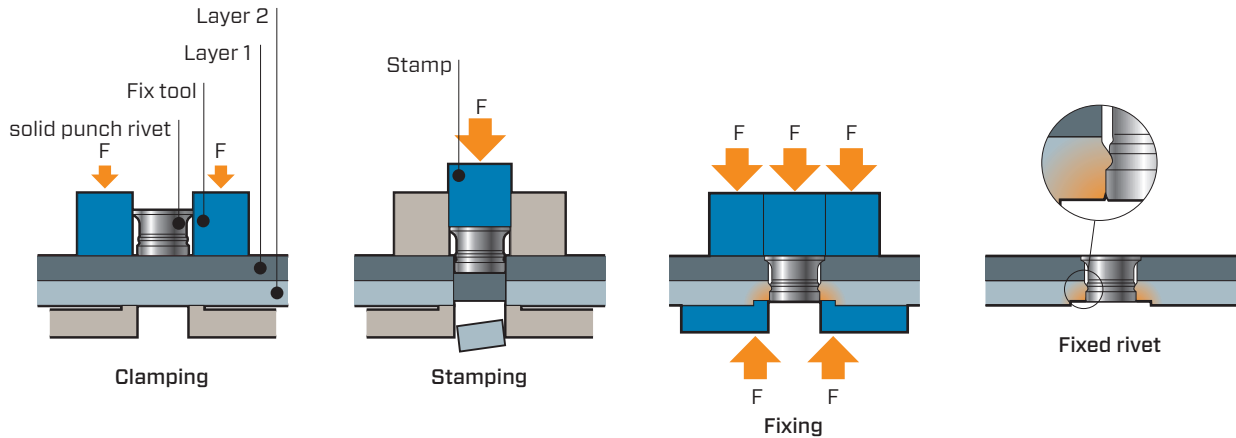

TECHNICAL SPECIFICATION OF XPRIMO

- Diameter: 4 mm and 5 mm (shaft diameter)
- Length: 3.5 mm to 9 mm
- Strength: 1300 N / mm² - 1800 N / mm²
- Many technical surfaces are applicable
- Other custom sizes and shapes available on request

PROPERTIES OF SOLID PUNCH RIVETS

- Join different sheet material
- ALU/steel
- Steel / high tensile steel
- ALU / high tensile steel
- Join sheet metal with various thicknesses
- Combination with adhesive possible
- No heat introduction
- No pre piercing required
- Join 2 or 3 layer

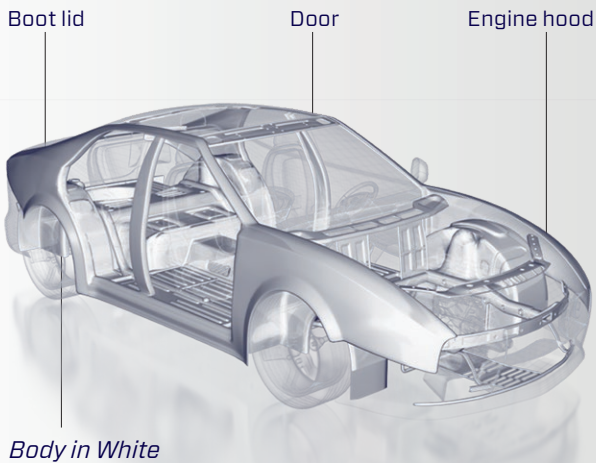

Body in White

ADVANTAGE TO TURNED SOLID PUNCH RIVETS

- Better fixation of coating
- Higher load capacity
- Lower risk of H2 embrittlement
- More cost effective

ADVANTAGE TO SEMITUBULAR RIVET

- Higher load capacity
- Usable for high tensile steel

Follow us:



For more than 130 years, Koninklijke Nedschroef Holding B.V. has developed, manufactured and supplied fasteners and special parts for the automotive industry. In addition, we design and produce superior forming machines and tools for the metal forming industry. Nedschroef delivers world-class services and innovative, cost-effective solutions. Our expanding global operations offer everything from product design and development to delivery, installation and service, supported by a vast global partner network. 2,400 people at 22 facilities in 11 countries worldwide are committed to our Full Service Provision concept.