

Nedlock®

Easy to assemble nuts with an all-metal locking feature



Nedschroef has created an innovative solution for the automotive industry's problems related to nuts with an all-metal locking feature. All-metal Nedlock® nuts can be screwed onto plain-finished bolts repeatedly - up to twenty times! - without sizing effects. Now, a wide variety of reliable connections can be made, on any type of bolt coating as well as on plain bolts. Nedlock outperforms other all-metal self-locking nuts due to its very low tendency to galling, which means plating on non-plated threaded parts is not easily damaged.

FIELD OF APPLICATION

Nedschroef NedLock® is perfect for difficult connections. OEM's can employ self-locking Nedlock® solutions for vital chassis connections, for example. The three top segments are highly elastic, allowing the nut to adapt itself to different types of bolt coating without sizing effects, loss of clamping torque or cold-welding. The excellent clamping torque makes these nuts ideal for fittings that need to be adjusted frequently.

Besides a broad selection of standard solutions, Nedschroef offers the integrated production, design and systems engineering capacity required to create bespoke solutions for even the most specific, demanding requirements at an attractive price point. Our engineers are ready to work together with you to create the ideal solution for your own application...

For more information: www.nedschroef.com

RADIAL TENSION FOR A PERFECT FIT

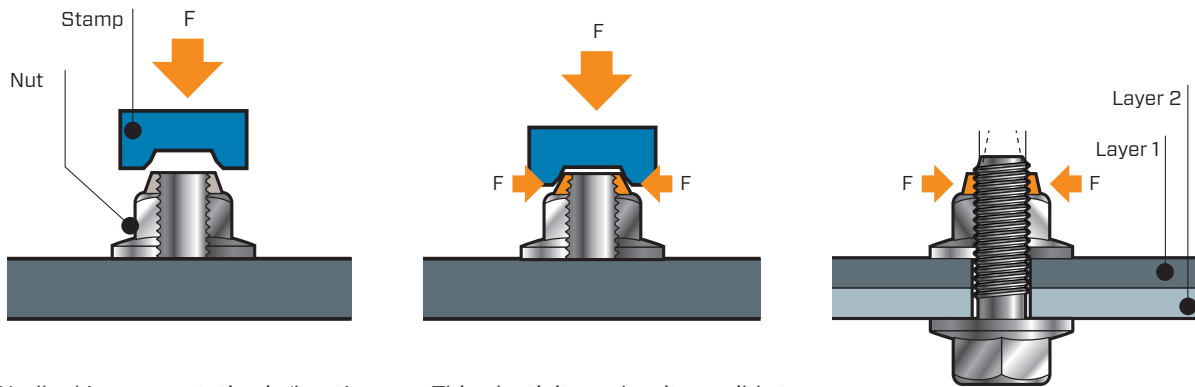

Nedlock's segmentation is 'bent' slightly inwards which results in a radial tension in the segment region, with largely elastic behaviour.

This elasticity makes it possible to screw Nedlock several times without a complete loss of clamping torque and seizing issues.

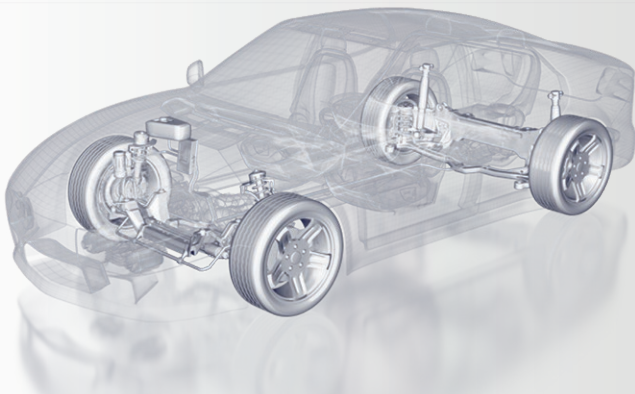

Ideal for frequently-adjusted fittings and chassis connections

DIMENSIONS

- Flange and hexagon nuts M8 to M22
- Property class: 04, 05, 8, 10, 12, YB, GA
- Can also be made according to customer specification

PROPERTIES

- All fastenings within Body-in-White, Chassis, Powertrain and Interior.
- Ideal for regularly adjustable fittings
- All-metal locking feature
- Highly elastic top segments

ADVANTAGES

- Easy to assemble
- Reliable connections on any coating
- Perfect for difficult connections
- No seizing effects
- Excellent clamping torque

Follow us:



For more than 130 years, Koninklijke Ned Schroef Holding B.V. has developed, manufactured and supplied fasteners and special parts for the automotive industry. In addition, we design and produce superior forming machines and tools for the metal forming industry. Ned Schroef delivers world-class services and innovative, cost-effective solutions. Our expanding global operations offer everything from product design and development to delivery, installation and service, supported by a vast global partner network. 2,400 people at 22 facilities in 11 countries worldwide are committed to our Full Service Provision concept.