

Tolerance absorber

Rigged fixing and tolerance absorption
in the blink of an eye



Nedschroef's Tolerance Absorber combines absorption with fixing, and can be processed by a single employee with one hand. The tolerance absorber combines two actions - absorption and fixing - into a single process step. The absorber is automatically pre-assembled, which saves OEMs a considerable amount of pre-mounting and adjustment time. During production at Nedschroef, 100% automatic checking takes place, using a gauge to ensure optimal thread function. At the OEM, screws can be positioned at an angle and the robust construction allows high torque values up to 25Nm and a tolerance absorption distance up to as high as 14mm.

FIELD OF APPLICATION

Perfect for applications such as tolerance absorbing and internal panel mounting for cockpits, car body sheet metal wing assembly, headlamp positioning and fixing and attaching the dashboard to the a-column. Besides a broad selection of standard solutions, Nedschroef offers the integrated production, design and systems engineering capacity required to create bespoke solutions for even the most specific, demanding requirements at an attractive price point. Our engineers are ready to work together with you to create the ideal solution for your own application...

For more information: www.nedschroef.com

ACCURATE POSITIONING AT AN ANGLE

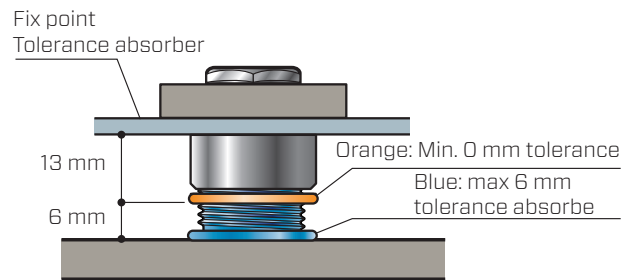
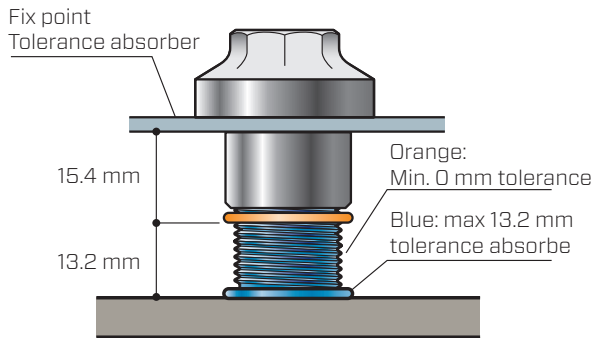

The outer part, with its welding humps, takes care of the initial attachment. The smallest metal part with M16 thread makes an axial rotation and bridges part of the distance. The smaller M8 thread ensures solid fixing.

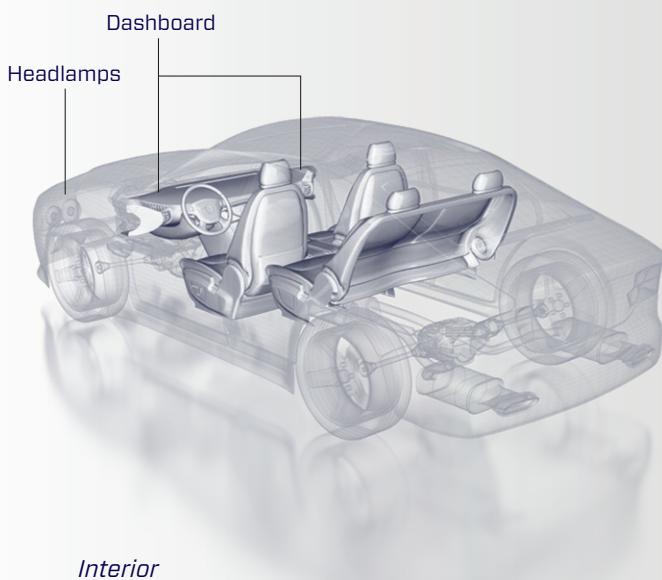

PROPERTIES

- Tolerance absorbing
- Internal panel mounting
- Combines absorption with fixing
- High torque values up to 25Nm
- Tolerance absorption up to 13.2 mm
- Cockpits
- Car body sheet metal wing assembly
- Headlamps

ADVANTAGES

- Can be processed by single employee
- One-handed operation
- 100% automatic checking during production
- OEM can position screws at angle
- One single process step

Follow us:



For more than 130 years, Koninklijke Nedschroef Holding B.V. has developed, manufactured and supplied fasteners and special parts for the automotive industry. In addition, we design and produce superior forming machines and tools for the metal forming industry. Nedschroef delivers world-class services and innovative, cost-effective solutions. Our expanding global operations offer everything from product design and development to delivery, installation and service, supported by a vast global partner network. 2,400 people at 22 facilities in 11 countries worldwide are committed to our Full Service Provision concept.